

**VETRINA REFRIGERATA +4+10°C
mod. PRISMA 100**



MATRICOLA:

RIFERIMENTO:
STK05-001

DIMENSIONI mm:
1052-436-510

PREZZO IVA ESCLUSA:
350 €

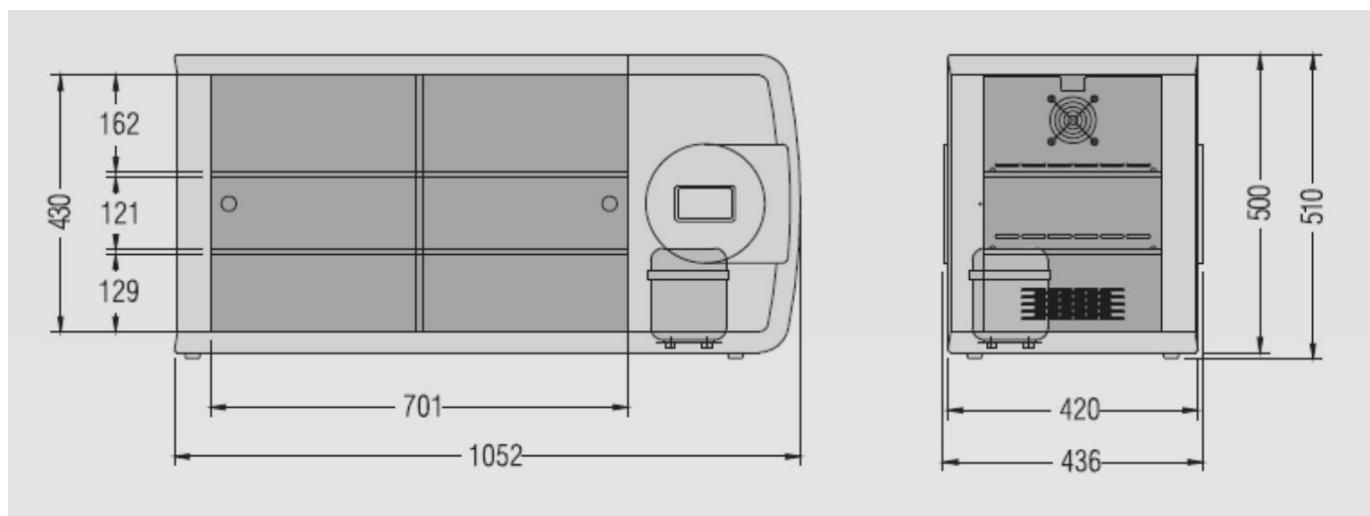

USATO

Vetrina refrigerata da appoggio, ventilata, sbrinamento automatico, vetri scorrevoli lato operatore, display elettronico